



Instructions for 9405 Dual-Channel Loop Detector

The 9405 loop detector is designed to be used with DoorKing vehicular gate operators only and controls two individual loops. The 9405 detector plugs into loop detector ports on the gate operator control board. The detector also employs several automatic and advanced features that will decrease "false" calls and assist technicians in the field with trouble shooting loop problems. Refer to the LOOPINFO manual for information on installing in-ground loops.

Sensitivity Boost

The sensitivity boost feature automatically increases the sensitivity of the loop detector when the detector is tripped by the passage of a vehicle over the loop. This prevents the detector from "losing" high bed vehicles as they pass over the loop. Boost can be set individually for each loop.

Fast-Trak

When Fast-Trak is turned on, the detector will track slow frequency shifts in the loop twice as fast as when this feature is turned off. This feature is useful on poor quality loops that drift in frequency. An indication of this would be when the detector has many "false" calls. Fast-Trak can be set individually for each loop.

Caution should be exercised when using the Fast-Trak feature. When Fast-Trak is turned ON, it will cause the presence time of the detector to be about half that of normal. That is to say, the detector will "tune out" vehicles that are parked on or near the loop about twice as fast as when this feature is turned off. **For this reason, we recommend that the Fast-Trak feature only be used as a temporary solution to loop frequency drift problems that are typically (but not always) caused by the use of poor quality wire in the loop itself.** If excessive frequency drift continues (indicated by many "false" calls), the loop itself will have to be replaced.

Frequency Measurement

Whenever the detector is powered up, or when the reset switch is pressed, the detector will blink out the frequency that the loop has tuned to (in KHz) on the CALL LED. Loop 1 will blink its frequency first followed by loop 2. For example, five blinks - pause - six blinks - pause - five blinks - pause - two blinks indicates that LOOP 1 has tuned to 56 KHz and LOOP 2 has tuned to 52 KHz.

This automatic frequency measurement is useful in applications where two or more loops and loop detectors are in close proximity to each other. A common problem with loop detectors "false calling" is because two or more loops in close proximity to each other are cross talking. Knowing what frequency the loop has tuned to allows you to reset the frequency on one of the detectors as far from the other detector as possible.

Loop Monitor

The loop detector constantly monitors the frequency of the loop to determine if the frequency is too high or too low, or if the loop has opened. When this happens, the detector will LOCK ON and the loop CALL LED will flash. If the frequency of the loop returns to nominal levels, the detector will resume normal operation but will continue to flash the CALL LED.

A flashing CALL LED is an indication that a problem exist in the loop itself and that the loop should be replaced. The CALL LED can be reset by pressing the reset button.

Plug the loop detector into the desired port for LOOP 1 operation (open, reverse) on the gate operator control board. The output of loop 1 is feed directly to the operator control board, or can be switched to a terminal. Refer to the gate operator installation manual.

Connect lead-in wires from loop 1 to the terminals marked LOOP 1. Set the frequency and operation switches as required.

Connect lead-in wires from loop 2 to the terminals marked LOOP 2. Set the frequency and operation switches as required. The frequency should be set different than loop 1 frequency.

The output of loop 2 is provided by a FORM C dry contact relay. Connect the relay terminals (C, NO, NC) as required.

POWER LED will illuminate whenever power is applied to the loop detector. L1 is the CALL LED for loop1 and L2 is the CALL LED for loop 2. These will illuminate when the detector senses a vehicle in the respective loop field and will also indicate the loop frequencies when the detector is powered up.

J1 jumper is set for LOOP 2 to operate in the PRESENCE mode. Removing this jumper will cause LOOP 2 to operate in the PULSE mode (relay activates for 250 ms, then drops out). LOOP 1 always operates in the PRESENCE mode.

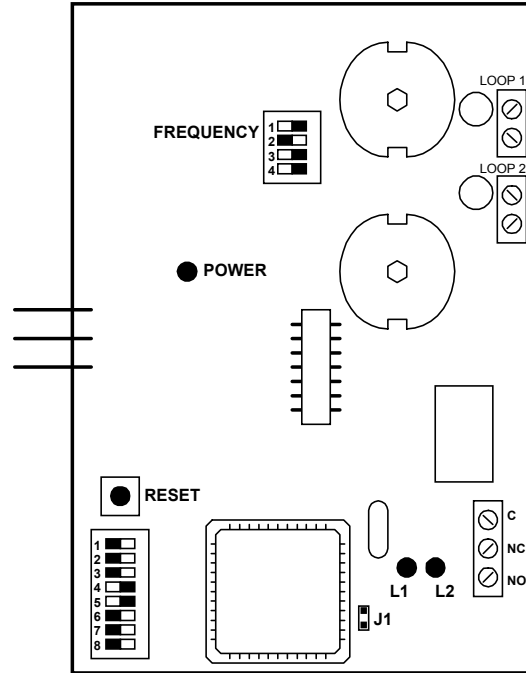

Pressing the RESET button clears faults and resets the detector.

LOOP FREQUENCY ADJUSTMENT				
	LOOP 1		LOOP 2	
	Switch 1	Switch 2	Switch 3	Switch 4
High	OFF	OFF	OFF	OFF
Med-High	OFF	ON	OFF	ON
Med-Low	ON	OFF	ON	OFF
Low	ON	ON	ON	ON

LOOP DETECTOR OPERATION ADJUSTMENTS								
	SENSITIVITY				FAST-TRAK		BOOST	
	LOOP 1		LOOP 2		LOOP 1	LOOP 2	LOOP 1	LOOP 2
	Sw 2	Sw 3	Sw 6	Sw 7	Sw 1	Sw 5	Sw 4	Sw 8
Low	OFF	OFF	OFF	OFF	OFF-Normal ON-FastTrak Engaged	OFF-Normal ON-FastTrak Engaged	OFF-Normal ON-Boost Engaged	OFF-Normal ON-Boost Engaged
Med-Low	OFF	ON	OFF	ON				
Med-High	ON	OFF	ON	OFF				
High	ON	ON	ON	ON				