

# TAS250

## Telephone Access System

### Installation Manual



FAAC International Inc. Headquarter &  
East Coast Operations  
5151 Sunbeam Road Suites 9-11  
Jacksonville, FL 32257  
Tel. 866 925 3222  
[www.faacusa.com](http://www.faacusa.com)

FAAC International Inc.  
West Coast Operations  
357 South Acacia Avenue Unit 357  
Fullerton, CA 92831  
Tel. 800 221 8278

**FAAC**



---

## Table of Contents

<b>General Description</b> .....	<b>1</b>
Pre-Installation Information.....	1
Safety Instructions .....	1
Technical Support.....	2
Compliance Specifications.....	3
Overview.....	5
Features .....	6
Optional Accessories .....	7
<b>1 - System Architecture</b> .....	<b>11</b>
<b>2 - Technical Specifications</b> .....	<b>15</b>
<b>3 - Electrical Specifications</b> .....	<b>16</b>
<b>4 - Installing the TAS250</b> .....	<b>17</b>
4.1 Preparing to Install the TAS250 .....	17
4.2 Installation .....	17
<b>5 - Troubleshooting</b> .....	<b>25</b>
<b>6 - Heartbeat Patterns</b> .....	<b>26</b>
<b>7 - Hardware Default initialization</b> .....	<b>27</b>
7.1 How to reset the FAAC Telephone Access System for Factory Default .....	27
<b>8 - Maintenance Recommendations</b> .....	<b>28</b>
<b>Appendix A - Installation Checklist</b> .....	<b>29</b>
<b>WARRANTY</b> .....	<b>30</b>

---

---

# General Description

## Pre-Installation Information

To the Installer: If you are familiar with the installation, you can jump to section **4 - Installing the TAS250** or use the **Appendix A - Installation Checklist on page 31** of this manual.

## Safety Instructions

**Important:** NEVER INSTALL THE EQUIPMENT DURING A LIGHTNING STORM!

This equipment, FAAC Telephone Access System, shall be installed and used within an environment that provides the pollution degree max 2 and over voltages category II NON HAZARDOUS LOCATIONS, INDOOR and OUTDOOR. The equipment is FIXED and PERMANENTLY CONNECTED and is designed to be installed by Service Persons only; [service person is defined as a person having the appropriate technical training and experience necessary to be aware of hazards to which that person may be exposed in performing a task and of measures to minimize the risks to that person or other persons.] The equipment is installed in a metallic cabinet that meets the applicable requirements for a FIRE ENCLOSURE.

1. The **connection to the mains supply** must be made as per the local authorities rules and regulations  
An appropriate disconnect device must be provided as part of the building installation. Where it is not possible to rely on the identification of the NEUTRAL in the AC MAINS SUPPLY, the disconnecting device must disconnect both poles simultaneously (LINE and NEUTRAL).
  - Be permanently connected, fail safe, with double or reinforced insulation between primary and secondary circuits.
  - The ground connection must be provided by the TERMINAL BLOCK at the PE (IEC 60417-5019 symbol) marked connection. It is the installer's responsibility to provide protection against a short circuit on the input (bridge rectifier, C2, etc.).
  - The system requires the integrity of the subscribed telephone line to be operational at all times. If the telephone line is cut off, placed out of service, or shared with other interconnect telephone devices other than the TAS250, the unit will not be able to perform its function when required.
2. AVOID **setting up** the equipment near heaters, air conditioners, ventilators. DO NOT select a place that exposes the TAS250 to vapors, chemicals or dust.
3. If **during the installation** a knockout on the cabinet is removed, it is the installer's responsibility to ensure that the same degree of protection for the cabinet is provided by the use of bushings, fittings, adequate sealant, etc.
4. The metallic **cabinet must be secured to the building structure before** operation.
5. The **ground connection** must be as shown within the included diagram, or equivalent.
6. **Internal wiring** must be routed in a manner that prevents:
  - Excessive strain on wire and on terminal connections;
  - Loosening of terminal; connections;
  - Damage of conductor insulation.
7. It is the end-user and/or installer's responsibility to ensure that the disposal of the used batteries is made according to the waste recovery and recycling regulations applicable to the intended market.
8. There are **no serviceable parts within the equipment**; For any issues regarding the equipment please contact your installer.
9. **CAUTION:** To reduce the risk of fire, use only AWG #26 or larger telecommunication line cord.
10. **CAUTION:** Risk of explosion if battery is replaced by an incorrect type. Dispose of used batteries according to the instructions.
11. **Sealant application** is required on all mounting holes and removed knockouts. The draining holes must **not** be blocked by any excess of sealant.
12. **DISCONNECT POWER BEFORE SERVICING**

---

## **Technical Support**

For technical assistance with the FAAC Telephone Access System and other FAAC products, contact technical support, Monday to Friday from 8AM to 5PM Eastern.

---

## Compliance Specifications

### FCC & IC Compliance

- This device complies with FCC 2000 Part 15 Class B (Radiated Emissions, Residential, USA). Operation is subject to the following two conditions: (1) this device may not cause harmful interference, and (2) this device must accept any interference received including interference that may cause undesired operation. This class B digital apparatus meets all requirements of the Canadian Interference Causing Equipment Regulations. The FAAC Telephone Access System is also compliant with EN55022:1998, amendment 1:1995, Class B and CISPR 22.
- TIA968 (FCC part 68) Direct Connection to the PSTN (Public Switched Telephone Network) USA.
- FCC Registration Number: **ACTA US: V85OT01BTAS250125 REN: 01B**
- DOC - CANADA: The Canadian Department of Communications label identifies certified equipment. This certification means that the equipment meets certain telecommunications network protective, operational, and safety requirements. The Department does not guarantee the equipment will operate to the users satisfaction.
  - Before installing this equipment, users should ensure that it is permissible to be connected to the facilities of the local telecommunications company. The equipment must also be installed using an acceptable means of connection. The customer should be aware that compliance with the above conditions may not prevent degradation of service in some situations.
  - Repairs to certified equipment should be made by an authorized Canadian maintenance facility designated by the supplier. Any repairs or alterations made by the user to this equipment, or equipment malfunctions, may give the telecommunications company cause to request the user to disconnect the equipment.
  - Users should ensure, for their own protection, that the electrical ground connections of the power utility, telephone lines, and internal metallic water pipe system, if present, are connected together. This precaution may be particularly important in rural areas.
  - CAUTION: Users should not attempt to make such connections themselves, but should contact the appropriate electric inspection authority, or electrician, as appropriate.
  - In addition, the FAAC Telephone Access System complies with the CS-03 (Direct Connection to the Public Switched Telephone Network, Canada).
  - DOC registration Number: **IC: 5690B-TAS250125**

---

## UL Compliance for the TAS250-125US and the TAS250-125CDN Models only

The FAAC Telephone Access System (TAS250) complies with the UL 294 which is described by the following: UL Standard for Access Control Equipment, USA. The TAS250 enables users to grant access to the building, to their visitors, via their own telephone line or cellular telephone. The TAS250 also supports basic schedule operations for the postal lock supervision and automatic relay activation.

- The TAS250 can be connected to the PC via IP or RS-485 or internal PTSN to the phone line, these are all supplementary. The TAS250 must be connected to one of the compatible controllers (KT-300, or KT-400).
- Use only a UL listed transformer available through FAAC distributors or dealers, please refer to the Technical Support contact information to obtain the specific transformer, see page 2.
  - **FAAC part number TR1640P/UL** (manufacturer part number Codex model SEP-1640U)
  - **FAAC part number TR1640P/CSA** (manufacturer part number Codex model SEP/G-1640)
- For UL 294:
  - Only models TAS250-125US (for installation in the USA) and TAS250-125CDN (for installation in Canada) are UL listed.
  - If the TAS250 door lock output is used in fail-secure mode, a listed panic hardware device shall be used to allow emergency exit from the protected area.
  - Electrical specifications, refer to **Table 1 on page 15** and **Table 2 on page 16**.
  - For class 1 installation, the optional camera need to be installed.
- Each TAS250 will be battery backed up with a KT-BATT-12, 12V/7Ah battery.
- The optional accessories allowed in a UL installation are:
  - Heater kit (part number TAS250-HEAT)
  - Postal lock (part number TAS250-POSTAL)
  - Color camera (part number TAS250-CAM-N)
- The TAS250 is an access control accessory.
- Humidity test conducted at 90%.
- Compatible card readers are: P225, P325, P600 and Polaris.
- The TAS250 has an on-board capability of monitoring 4 input points. Each onboard input is supervised with or without end-of-line resistors (5.6K ohm). The maximum distance of one line is 600 m (2,000 ft) with AWG #22 in a single or double EOL configuration.



## Overview

The FAAC Telephone Access System enables users to grant access to the building, to their visitors, via their own telephone line or cellular telephone. This telephone line can also serve, via an integrated modem, as a programming link and/or a monitoring link. Programmed alarms and troubles can be reported to a pager. The TAS250 also supports basic schedule operations for the postal lock supervision, automatic door unlock, automatic relay activation, pager and dialup reporting.

The TAS250 is designed to be a stand-alone unit as well as a part of a complete access control system such as EntraPass from FAAC. The TAS250 can be connected to a PC via IP or RS-485 or internal PSTN to the phone line. It can communicate with EntraPass through a Corporate gateway for programming and monitoring.

This manual will describe the installation procedures required to install and power up the TAS250. For the configuration of the TAS250, refer to the TAS250 *Programming Manual*.

**Figure 1: Front Panel Description**



---

## Features

### Compatible with any Access Controller Supporting a Wiegand Interface Port

- Any access controller with Wiegand reader port(s)

### Compatible with all EntraPass Special, Corporate and Global Editions

The FAAC Telephone Access System is compatible with all EntraPass Editions v4.02 and higher:

- EntraPass Special Edition
- EntraPass Corporate Edition with a Corporate Gateway
- EntraPass Global Edition with a Corporate Gateway

### Multiple Configuration Options

- **Visual User Interface (VUI):** The TAS250 can be configured locally with the VUI, refer to the *Programming Manual*, for details concerning the VUI.
- **EntraPass:** The TAS250 can be configured and monitored through the EntraPass system, refer to the corresponding *EntraPass Reference Manual*, for additional details.

### Communication Ports

- 1 10/100Base-T Ethernet for network connection with the EntraPass Gateway
- 1 (TIP and RING) terminal block for phone line connections and for multiple TAS250 sharing the same telephone line
- 1 RS-485 (COM1) for RS-485 communication with the EntraPass Gateway

### Inputs

There are four (4) onboard inputs on the TAS250. They are configurable with EOL (End-of-Line) resistor, without EOL resistor, or with double EOL resistors. Respective alarm response timers are also programmable. By default, Input 1 is assigned to the door contact and Input 2 is assigned to the postal lock. Each input can be individually configured for one of the following applications:

- Door Contact
- Postal Lock
- Rex (Request to Exit) Device
- General Supervised Input

### DC Powered Lock Output

There is one (1) onboard DC powered lock output and it is supervised.

### Relay Outputs

There are three (3) onboard relay controlled outputs. The locking function can also be performed by any onboard relay configured for lock output functionality.

### Reader Interfaces

There are two (2) onboard reader interfaces. They can be programmed for one (1) Wiegand input port and one (1) Wiegand output port.

### Automatic Port Detection

The TAS250 can automatically detect the site communication RS-485 speed set by EntraPass as well as the communication port which can be IP (ETHERNET #1), RS-485 (COM1) or Dialup modem.

### Upgradable Firmware

The firmware program can be downloaded from any EntraPass workstation to the TAS250. The firmware program, stored in the TAS250 flash memory, is upgraded without having to change any parts.

### Trouble and Reporting

The TAS250 constantly supervises ac power and battery condition and reports “AC Lost”, “Normal Battery”, “Low Battery”, or “No Battery”, status to the EntraPass system. Power outputs are supervised and electronically protected against circuits surges. The locking device is also supervised for short to common and open circuit.

## Event Buffer

The event buffer can hold up to 4000 events.

## Visual Status Indicators (LEDs)

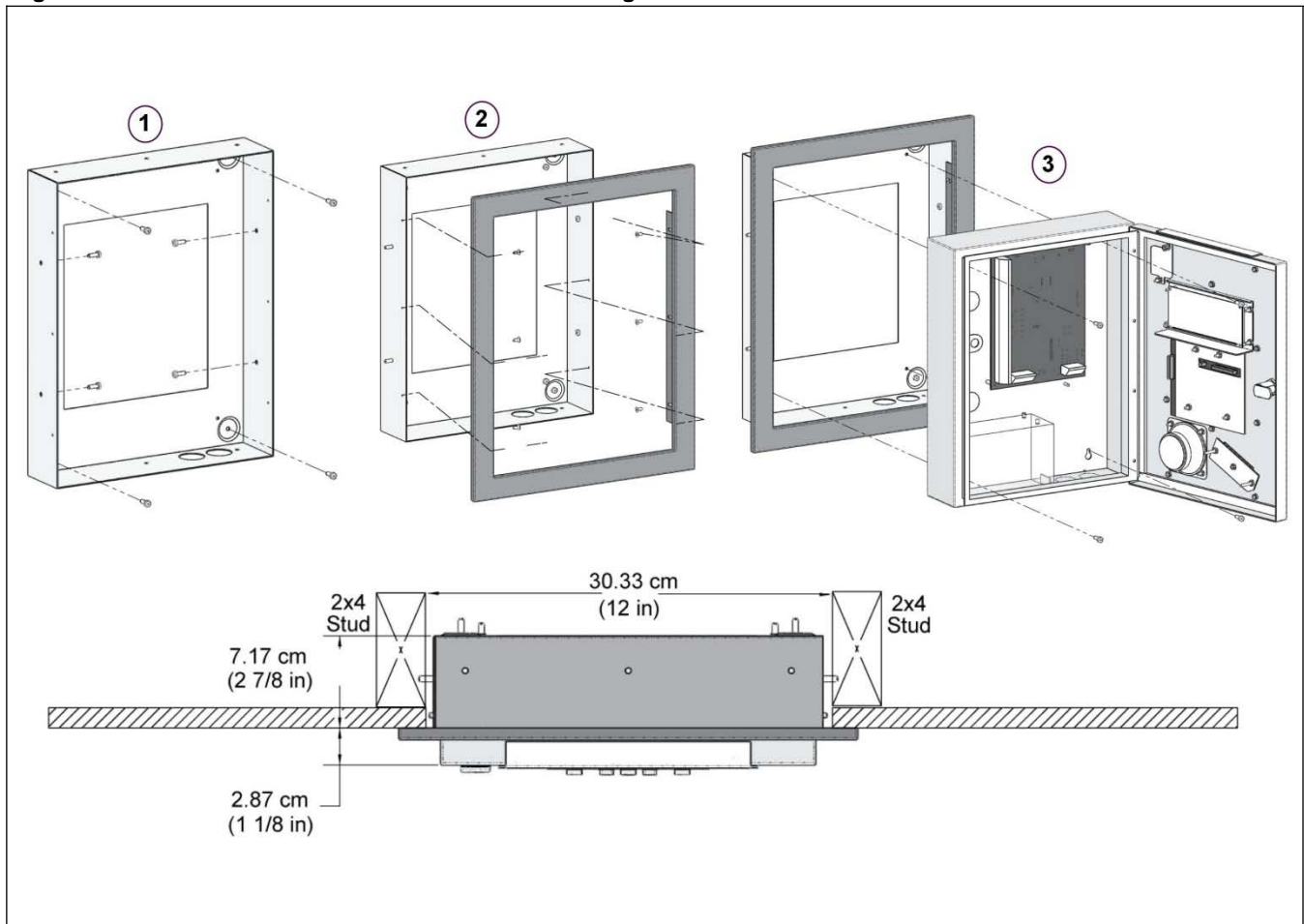
The TAS250 has multiple status indicators such as for troubleshooting, network activity, power status and outputs activity. See **Figure 8**: for their locations.

- **HEARTBEAT (BLUE)**: This LED indicates the working status of the TAS250. Refer to Table 6 for a description of the heartbeat patterns.
- **COM1 RX, COM1 TX (YELLOW)**: The RS-485 port LEDs are transmit/receive activity indicators.
- **COM2 RX and COM2 TX (YELLOW)**: For future use.
- **OFF-HOOK (RED)**: This LED turns ON when the TAS250 is either dialing or answering a call.
- **LOCK (RED)**: This LED turns ON when the lock output is activated.
- **RELAY1, RELAY2 and RELAY3 (RED)**: Each relay output has an indicator which turns ON each time the corresponding relay is activated.
- **AC POWER and DC POWER (GREEN)**: These LEDs are on when AC and DC power are present.
- **TXRX (YELLOW)**: This LED is OFF when there is no Ethernet network or the cable is disconnected; FLASHING when there is an Ethernet cable and network activity; and ON when the network is present.
- **100 (GREEN)**: This LED is ON when the TAS250 is connected to a 100 Base-T Ethernet network.

## Optional Accessories

The TAS250 can be mounted indoor or outdoor directly on the wall (surface mount) or recessed (flush mount). The surface mount is described **4 - Installing the TAS250**. The following figures describes the options available with the TAS250. Each option has its own install sheet included.

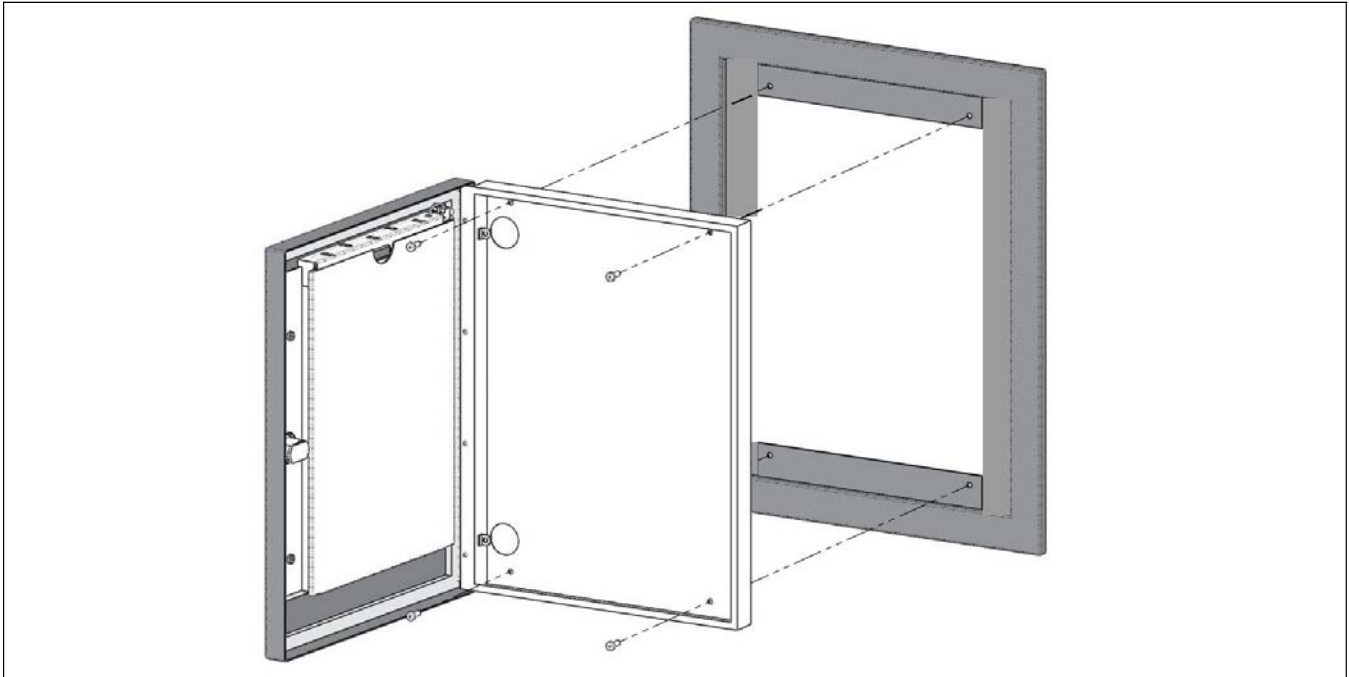
**Figure 2: TAS250 Flush Mounted with Box and Trim Ring**



### Matching Paper Directory

The TAS250 itself does not support a paper directory but has an optional matching enclosure designed just for that purpose. This illuminated enclosure supports the letter format 216 x 279 mm (8.5 x 11 in) and A4 format 210 x 297 mm (8.3 x 11.7 in).

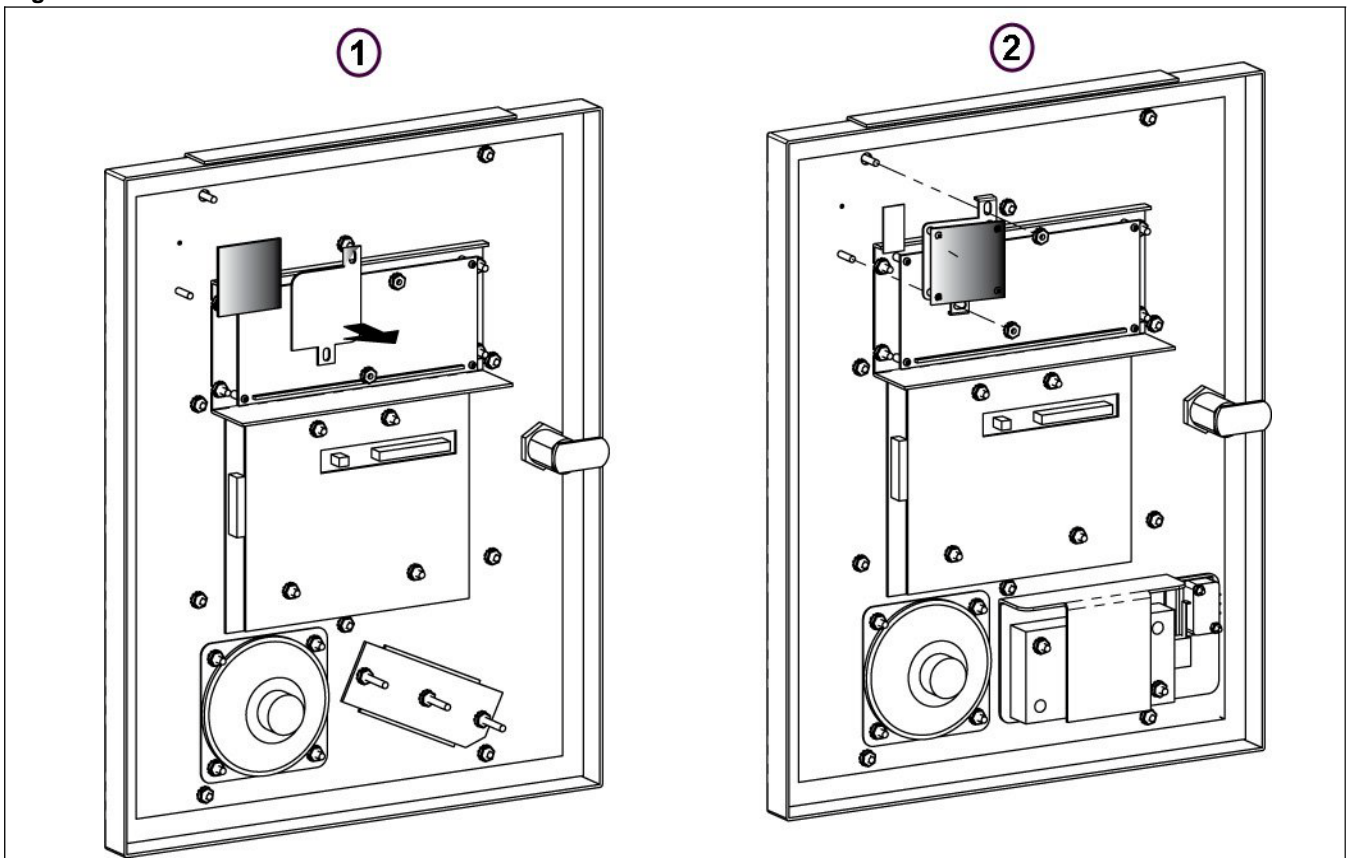
**Figure 3: Paper Index Flush Mounted**



### Camera

The TAS250 offers the possibility to install a color camera in the back of the front door.

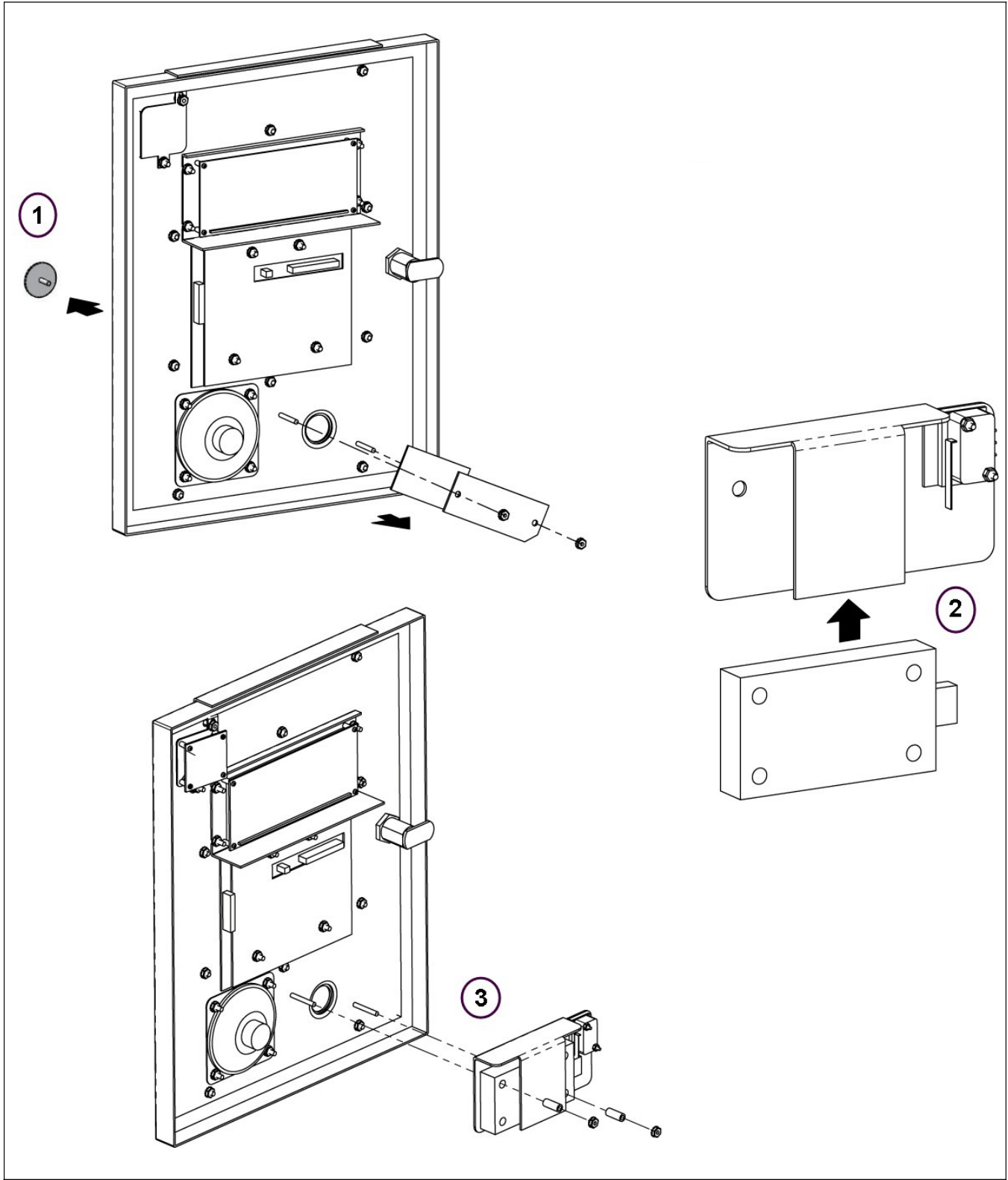
**Figure 4: Camera Position in Back of Front Door**



## Postal Lock

This option fits in the product enclosure. Its role is to allow postal service personnel access to the building. For added security purpose its usage may be limited by a schedule.

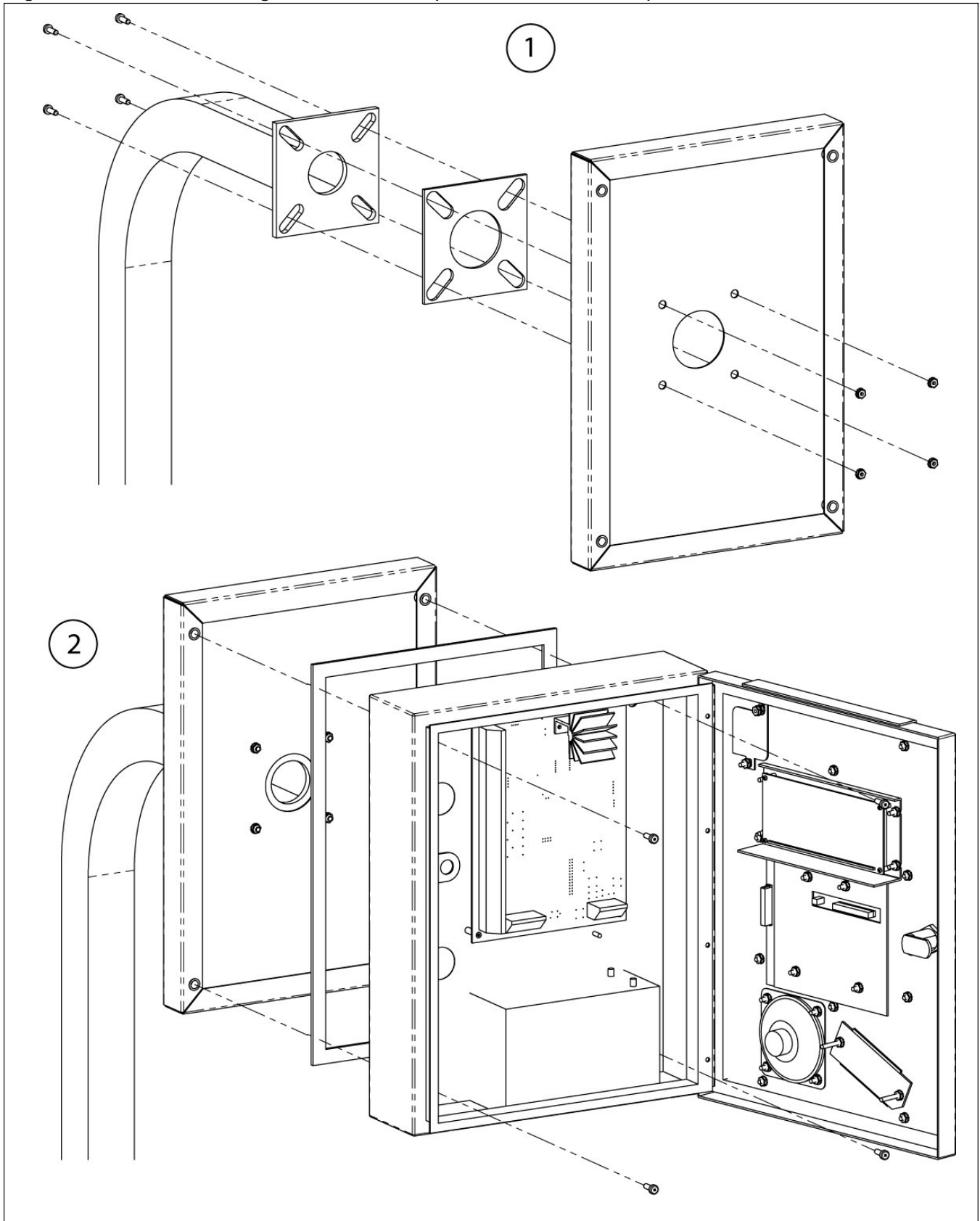
Figure 5: Postal Lock Mounting Location



## Goose Neck

The TAS250 can be mounted on a goose neck stand.

**Figure 6: Goose Neck Mounting Plate with Gaskets (Goose Neck not Included)**



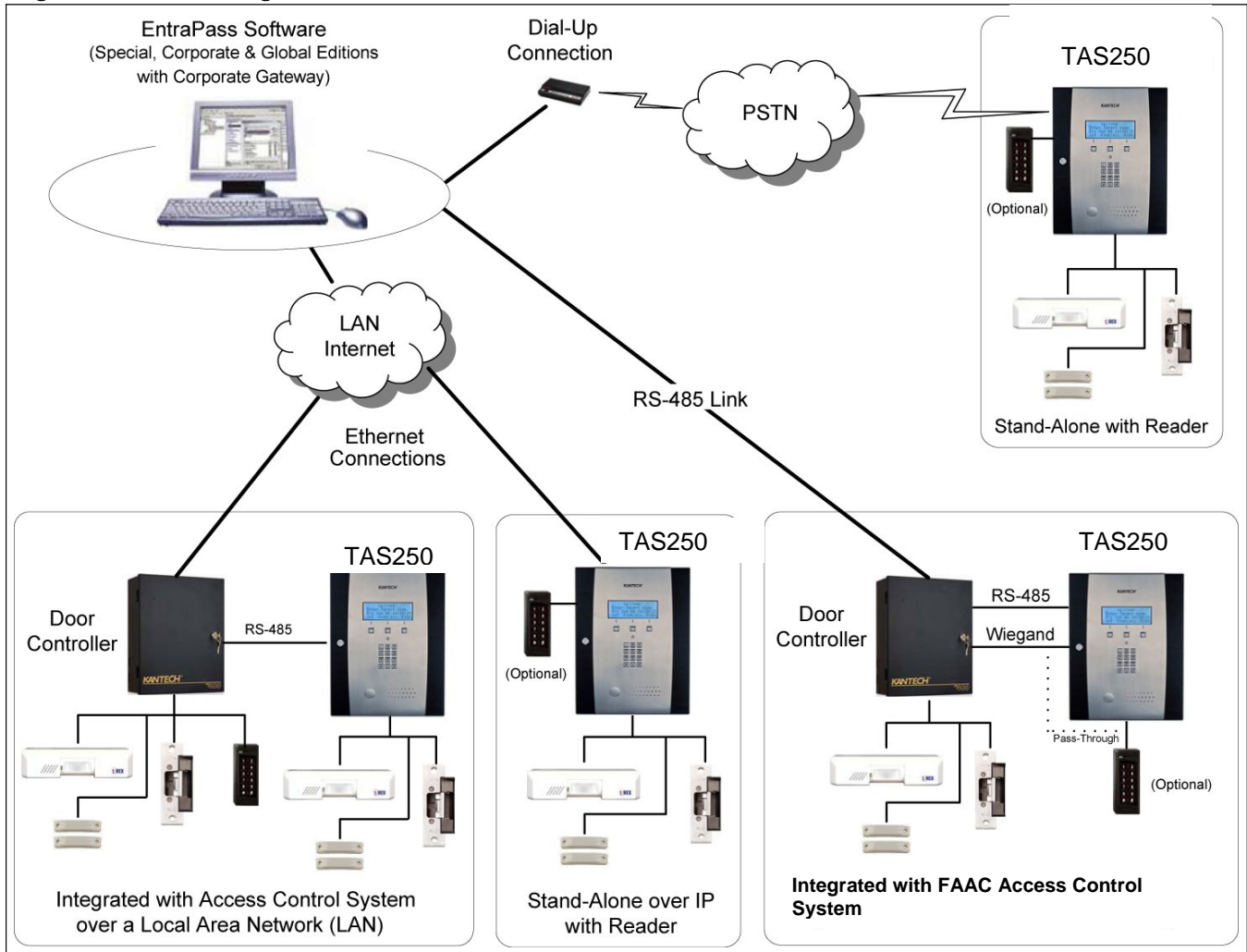


# 1 - System Architecture

The TAS250 can be configured and monitored through various means:

- Locally with the Visual User Interface (VUI).
- Remotely with EntraPass over an Ethernet network.
- Remotely with EntraPass over RS-485.
- Remotely with EntraPass over the telephone line with a dialup modem.

**Figure 7: TAS250 Configurations with EntraPass**



**Note:** For the UL 294 Compliance, the TAS250-125US and TAS250-125CDN models must be integrated with an access control system over a Wiegand connection.

Figure 8: PCB view of main board

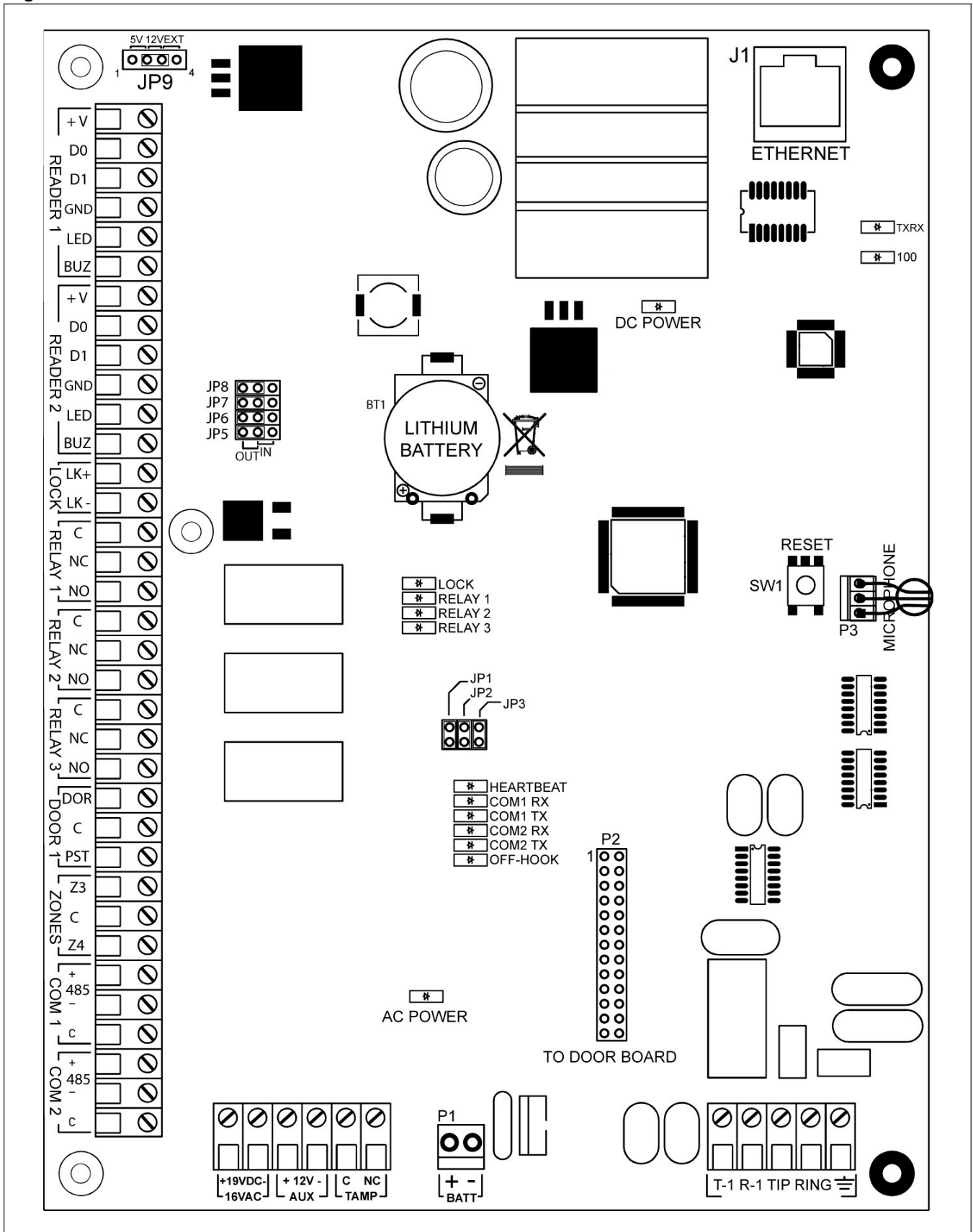




Figure 9: TAS250 Wiring Example with an External Controller - UL Compliant (North America)

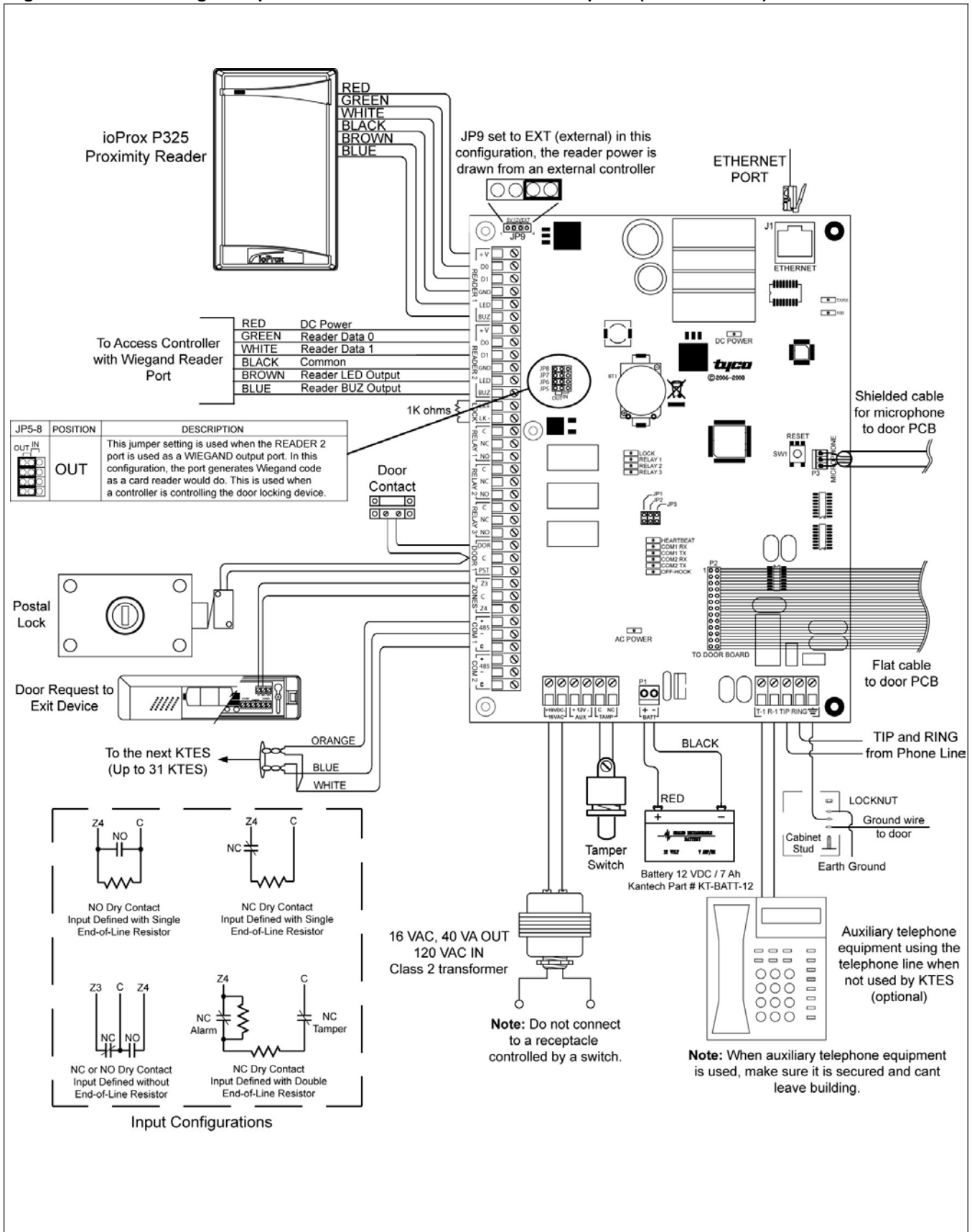
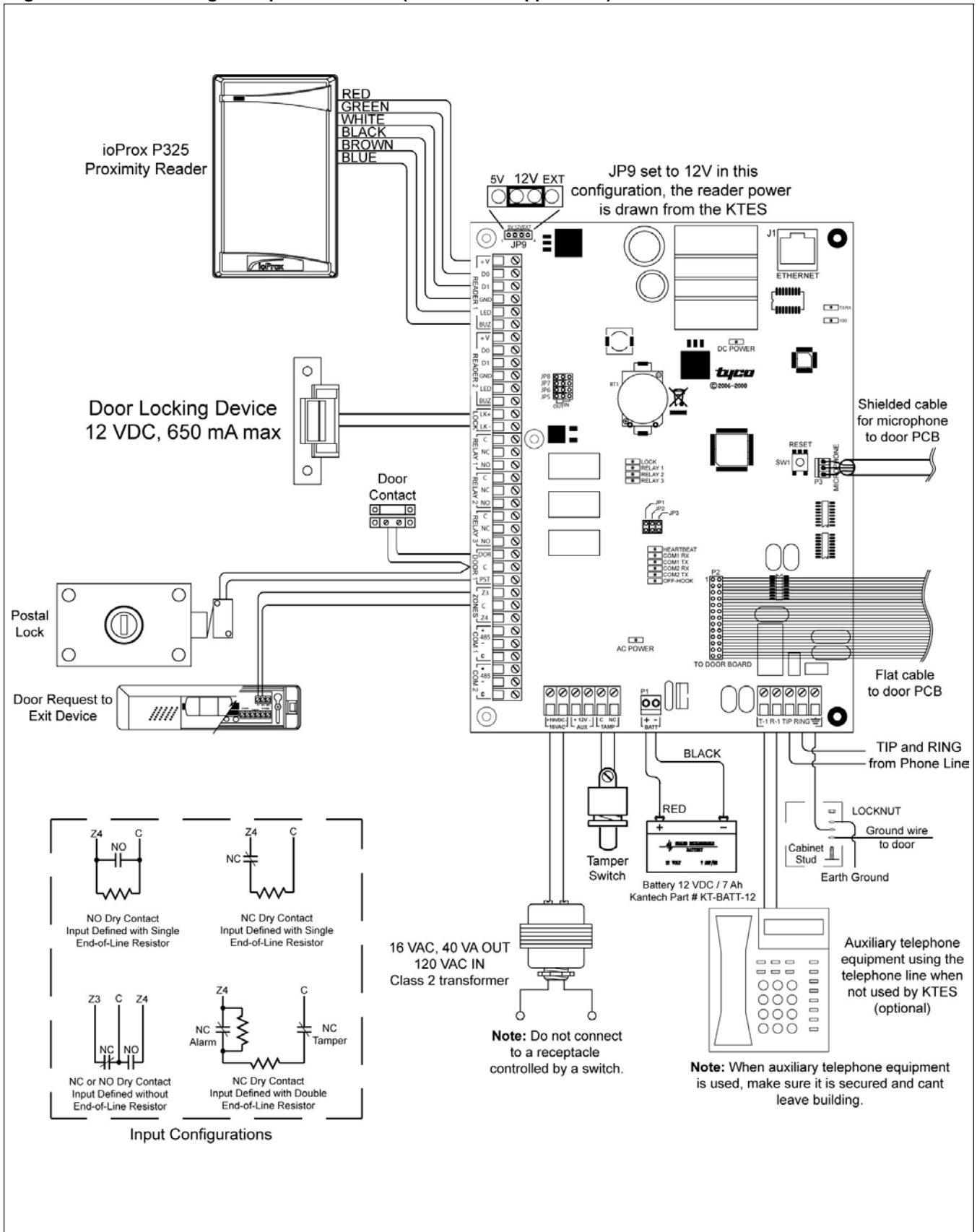


Figure 10: TAS250 Wiring Example with Reader (Stand Alone Application) - North America



## 2 - Technical Specifications

**Table 1: Technical Specifications**

Specification	Description
AC Power Input (UL)	16.5 VAC, 40 VA, 1.9 Amps class 2 transformer, see <b>Table 3 on page 25</b> for the part numbers
DC Power Input (CE)	19 VDC, 3.15 Amps, see <b>Table 3 on page 25</b> for the part numbers
DC Auxiliary Output	11.2 to 13.75 VDC, 450 mA
Lock Output	11.2 to 13.75 VDC, 650 mA
Relay Controlled Outputs	<ul style="list-style-type: none"> <li>• 3 Form C Relay controlled outputs</li> <li>• 30 VDC, 3 Amps max each, or</li> <li>• 24 VAC, 3 Amps max each</li> </ul>
Reader Power Outputs (JP9)	3 options with jumpers (JP9): <ul style="list-style-type: none"> <li>• 5 VDC, 175 mA, or</li> <li>• 12 VDC, 175 mA, or</li> <li>• from external controller</li> </ul>
Auxiliary Reader Outputs	2 outputs per reader (LED and BUZ), 25 mA max. each, open collector outputs
Reader types	Wiegand interface
Monitored Points (Zone Inputs)	<ul style="list-style-type: none"> <li>• 4 monitored points (Z1 to Z4), NO/NC, with or without EOL resistor</li> <li>• 1 fixed-function tamper switch input</li> </ul>
Points maximum wiring	AWG #22 - 600 m (2,000 ft.)
Weight (UL Listed)	7.0 kg (15.4 lb)
Weight (CE Compliant)	7.0 kg (15.4 lb)
Visual User Interface (VUI) Characteristics	4 lines x 20 Characters LCD module with controllable LED backlighting. The text on the 4th line cant be edited, but can be changed with the navigation buttons.
Operating Temperatures	Without heater kit: -10°C to 55°C (14°F to 131°F) With heater kit: -40°C to 55°C (-40°F to 131°F)
Humidity Level	Indoor and outdoor: 0 to 90%
Storage Conditions	Temperature: -40°C to 70°C (-40°F to 158°F)
Multiple TAS250 Cabling	Telephone Line: 305 m (1,000 ft.) maximum RS-485 Bus: 1219 m (4,000 ft.) maximum Ethernet network: 91 m (300 ft.) maximum
TAS250 Dimensions (Surface Mount)	29.21 cm (11 1/2 in.) Wide x 37.46 cm (14 3/4 in.) High x 9.91 cm (3.9 in.) Deep
Communication ports	10/100 Base-T Ethernet Port (RJ-45 connector) 1 x RS-485 (COM1) Global Data Access Arrangement (DAA) interface for the telephone line
Communication speed	<ul style="list-style-type: none"> <li>• Ethernet: 10/100 Base-T</li> <li>• RS-485: from 1200 to 115,200 Baud (automatic detection)</li> <li>• Dialup Modem: Up to 2400 Baud</li> </ul>
Flush Mount Box	30.33 cm (12 in.) Wide, 38.42 cm (15 1/8 in.) High, 7.15 cm (2 7/8 in.) Deep
Paper Index Flush Mount	29.21 cm (11 1/2 in.) Wide, 37.46 cm (14 3/4 in.) High, 2.82 cm (1 1/8 in.) Deep

**Table 1: Technical Specifications**

Specification	Description
Paper Index Surface Mount	29.21 cm (11 1/2 in.) Wide, 37.46 cm (14 3/4 in.) High, 9.93 cm (4 in.) Deep
Paper Index Black Trim Ring	35.72 cm (14 in.) Wide, 44.13 cm (17 3/8 in.) High, 0.92 cm (3/8 in.) Deep
Goose Neck Mounting Plate	25.30 cm (10 in.) Wide, 36.50 cm (14 3/8 in.) High, 3.30cm (1 1/4 in.) Deep

### 3 - Electrical Specifications

**Table 2: Electrical Specifications**

AUXILIARY OUTPUTS	MAXIMUM CURRENT	COMBINED MAXIMUM CURRENT
LED for each door reader	25 mA (each)	1.1 Amps
Buzzer (BUZ) for each door reader	25 mA (each)	
OUTPUTS	MAXIMUM CURRENT	
1 for Auxiliary Power (11.2 to 13.75 VDC)	450 mA	
2 for Controlled Readers (11.2 to 13.75 VDC)	175 mA	
2 for Controlled Readers (5 VDC)	175 mA	
1 for Lock Output (11.2 to 13.75 VDC)	650 mA	

## 4 - Installing the TAS250

**Important:** Make sure that the local telephone company has been notified that you will be installing communication equipment.

### 4.1 Preparing to Install the TAS250

A visual inspection should be made when unpacking the TAS250. Any missing item/part or damaged component should be reported immediately.

#### Stay away from electrical or communication devices

The TAS250 has been designed to be mounted indoor or outdoor. The cabinet is large enough to accommodate the backup battery and the necessary wiring connections for most applications. Four (4) EMT (Electrical Metallic Tubing) conduit knockouts (1.9 cm (0.75 in)) are provided. The location should be easily accessible for servicing the equipment. The TAS250 must be located at a minimum distance of 2 m (6 ft) from any high voltage equipment or wiring and from electrical equipment susceptible of generating electrical interference and at a minimum of 8 m (25 ft) from any transmitting equipment.

### 4.2 Installation

#### STEP 1: Unpacking the TAS250

**Check that the following parts are in your TAS250 package when you unpack it:**

- FAAC Telephone Access System (TAS250)
- EntraPass software CD-ROM, version 4.02 or higher
- Installation Manual, English and French version
- Programming Manual, English and French version

Any missing item/part or damaged component should be reported immediately.

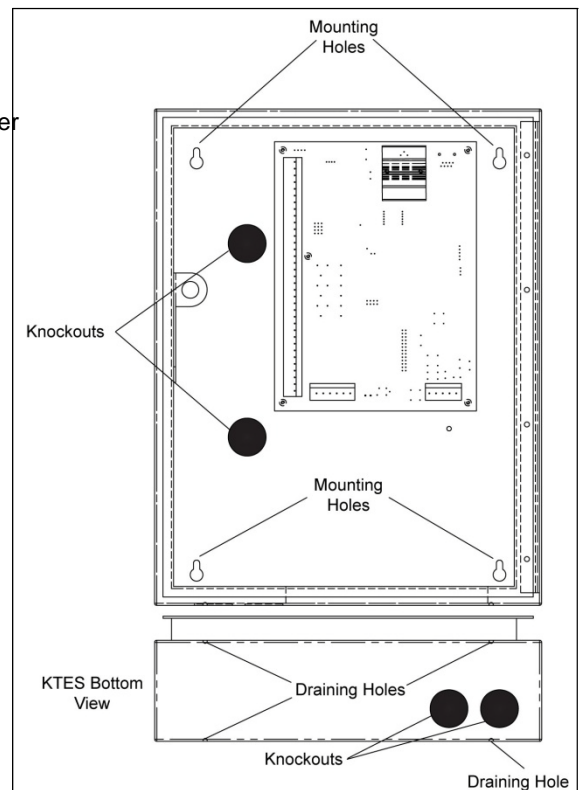
**Note 1:** The 12 VDC backup battery and the ground clamp are not included.

**Note 2:** Make sure you have adequate sealant (not included).

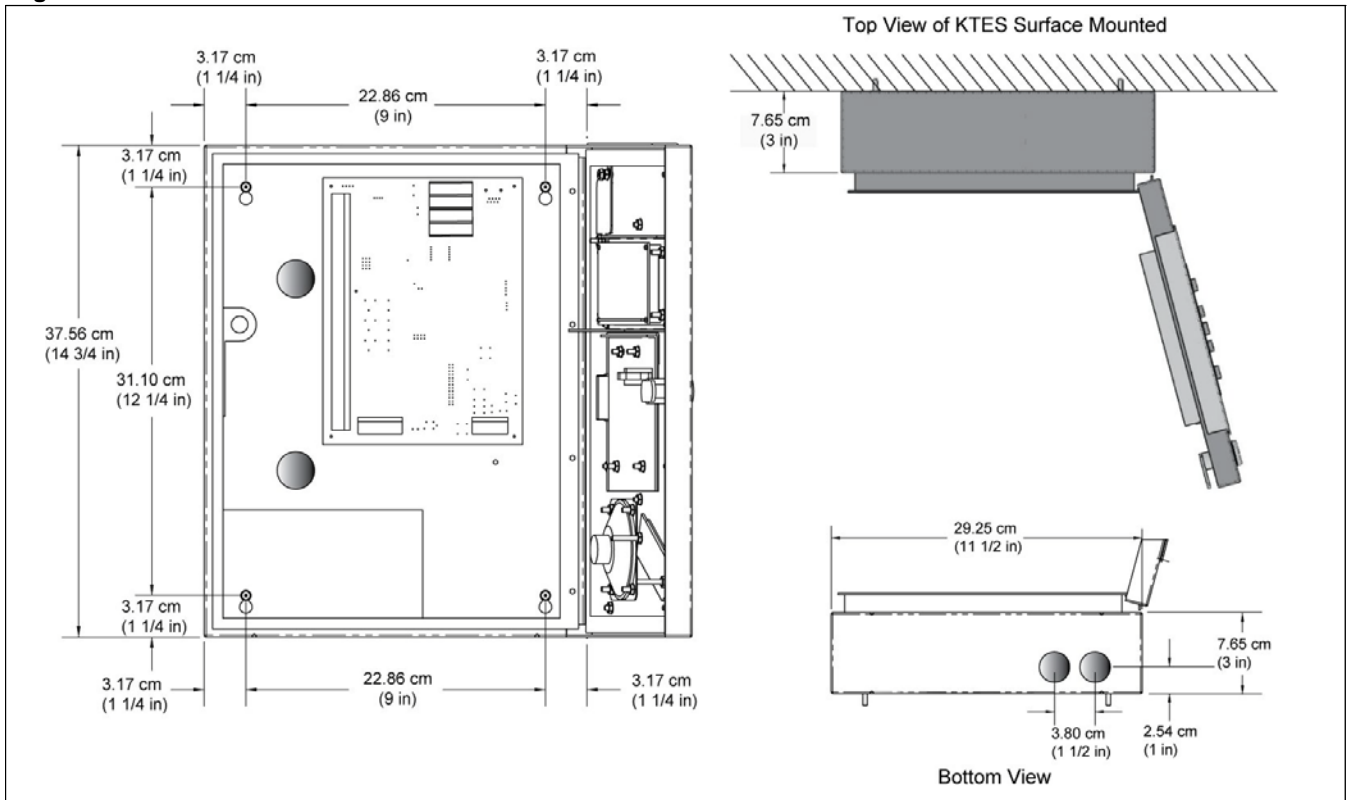
#### STEP 2: Applying Sealant on the Back of the TAS250

Sealant must be applied on each of the four mounting holes when the TAS250 is installed **outside** in order to avoid water infiltration. Also, apply sealant around any knockout that will be removed.

**Important:** Be careful not to apply sealant on the four (4) draining holes at the bottom of the TAS250.



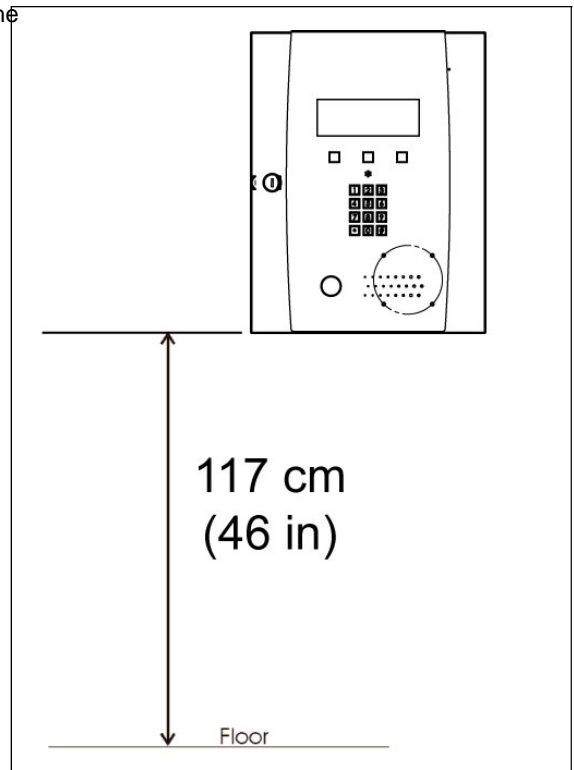
**Figure 11: Surface Mount Installation**



**STEP 3: Mounting**

It is recommended that you mount the TAS250 so that the bottom of the enclosure is not higher than 117 cm (46 in.) from the floor. If you install it in a location where there are extremely low temperatures, the outdoor installation might require an optional heater kit in order to meet the environmental conditions.

**Caution:** Make sure the area stays clear of any objects below the TAS250 that could interfere with its daily use.

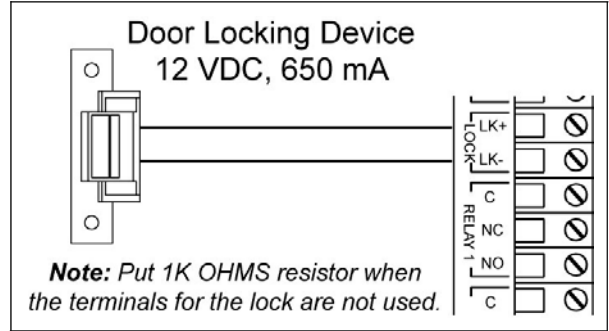


## STEP 4: Connecting the Door Locking Device (DC Powered)

### Connecting the Door Lock Device to LK+ and LK-

#### Check for Local “magnetic lock” Regulations

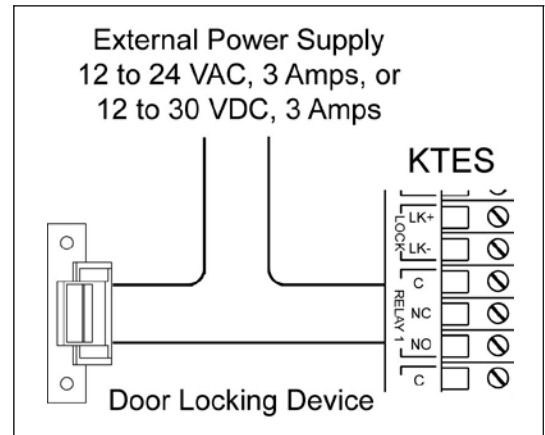
The door locking device output is controlled according to the end-user programmed parameters for allowing access to or unlocking doors according to schedules and access levels. The door locking device output can operate DC powered locking devices such as an electromechanical strike and can be configured to operate fail-safe or fail-secure (normal or reverse action).



**Note:** Use 1 K ohm EOL (End-of-Line resistor) between LK+ and LK- terminals if not used.

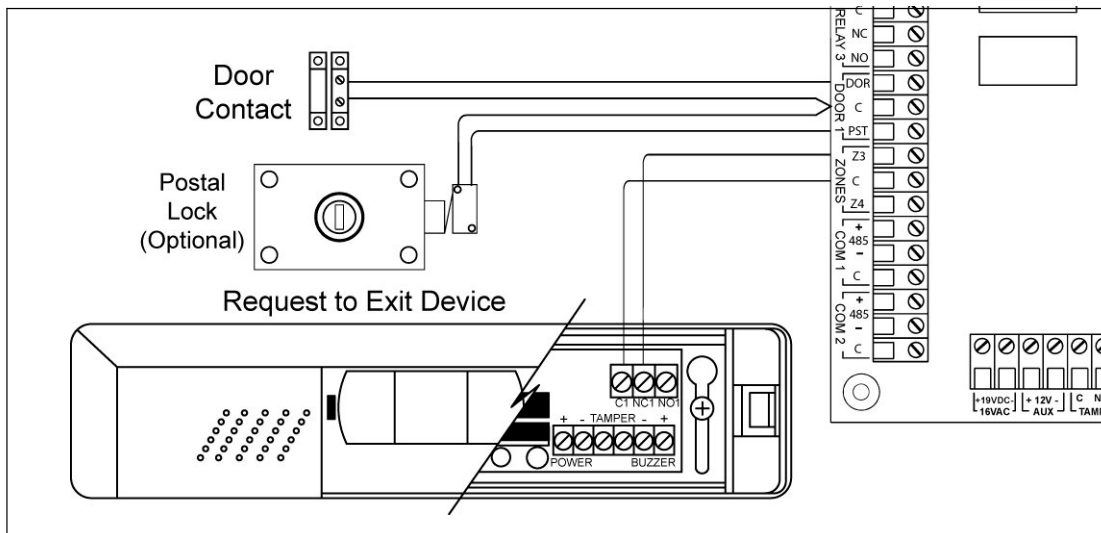
## STEP 5: Connecting the Door Lock Device with an External Power Supply

Use one of the three relay terminals available to connect the door locking device and the external power supply.



## STEP 6: Hooking Up Inputs

### Connect Devices to Inputs 1 to 4



**Note:** Onboard inputs can be defined with: none, single or double EOL (End-of-Line) resistor(s) according to your settings with the VUI or with EntraPass.

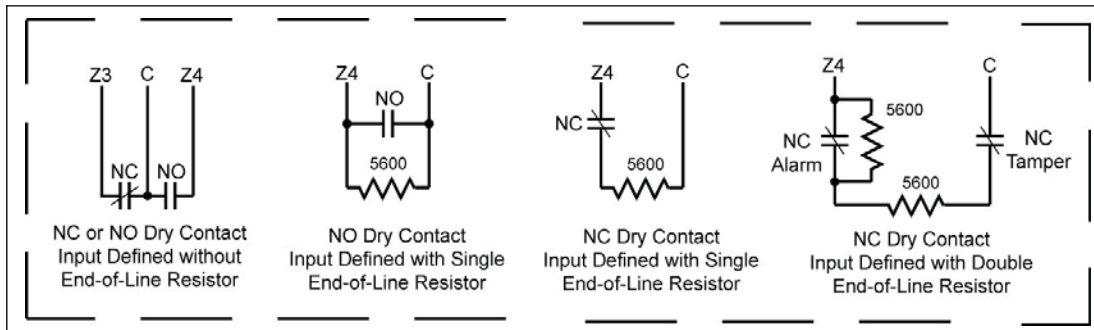
## Resistors for all Inputs 5.6K Ohms (EOL or DEOL) (Optional)

The TAS250 has an on-board capability of monitoring 4 input points. Each onboard input is supervised with or without end-of-line resistors (5.6K ohm). The maximum distance of one line is 600 m (2,000 ft) with AWG #22. Inputs 1-2 are automatically assigned. The **door contact** is assigned to input 1 and the **postal lock** is assigned for input 2. There is no obligation to follow these rules but this standard convention facilitates servicing.

**DRY (without EOL resistor):** In a simple NC dry contact configuration, the **secure** state is given when a short is detected. The **alarm** state is given when the input is open. If the alarm switch is programmed as NO device, the **alarm** state will be given when the input is shorted.

**EOL (with EOL resistor):** The **secure** state is given when a single resistor is detected. The **alarm** state is given when the input is open or short.

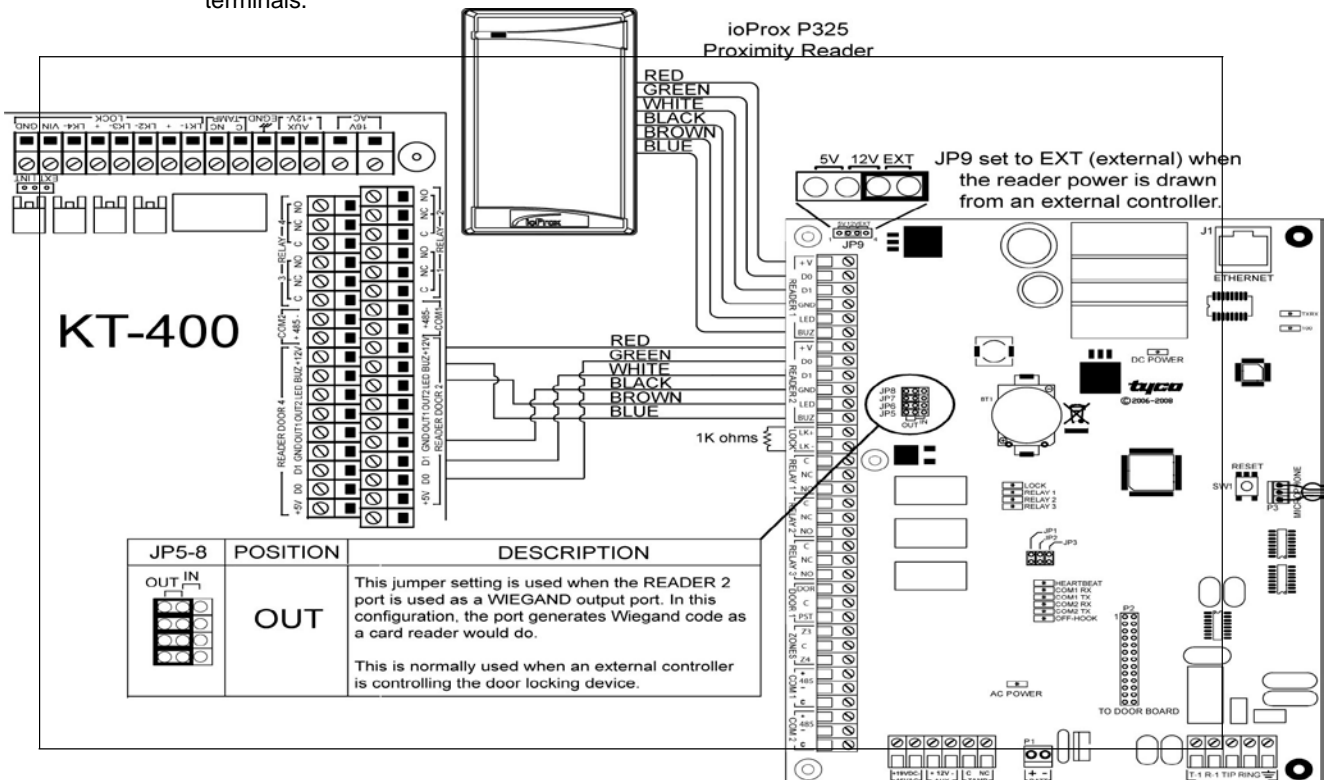
**DEOL (Double EOL Resistor):** For NC device only, in a DEOL configuration, the **secure** state is given when a single resistor is detected. The **alarm** state is given when two resistors in series are detected. The **trouble** state is given when the input is shorted. The **tamper** state is given when the input is left open.



## STEP 7: Connecting an External Controller

The distance between the reader and the TAS250 varies by reader type (please consult the installation manual for details).

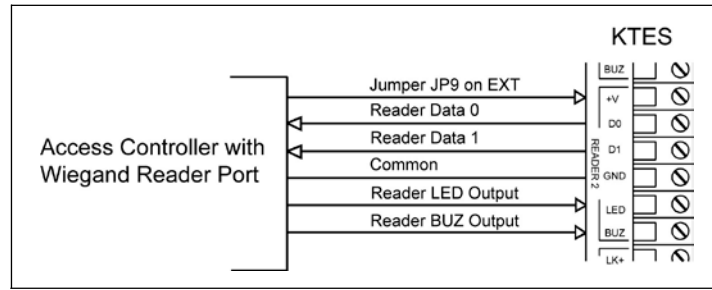
**Important:** When you want the external controller to power the reader, the jumper JP9 must be put on external (EXT) since the external controller will supply the +12 VDC to the reader connected on the **READER 1** terminals.





### STEP 8: Connecting a 3rd Party Controller

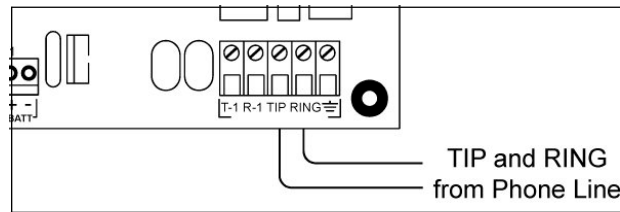
The +V terminal voltage level is set by jumper JP9 (5V, 12V or EXT).



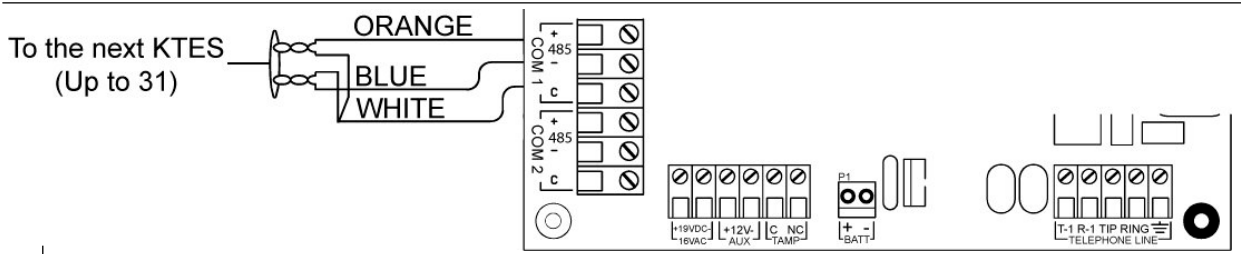
### STEP 9: Connecting the Telephone Line

Connect the TIP (green) and RING (red) from the Phone Line to the TIP and RING terminals.

**Note:** The (T-1 and R-1) terminals can be connected to the local telephone.

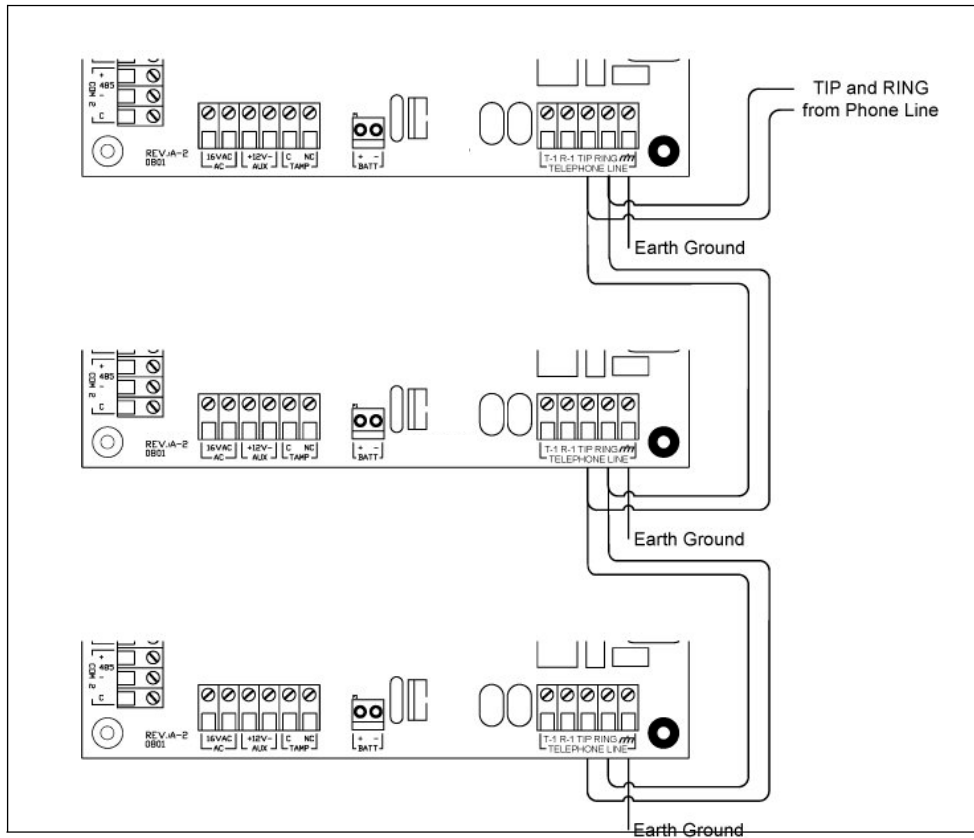


### STEP 10: Connecting the RS-485 (optional)



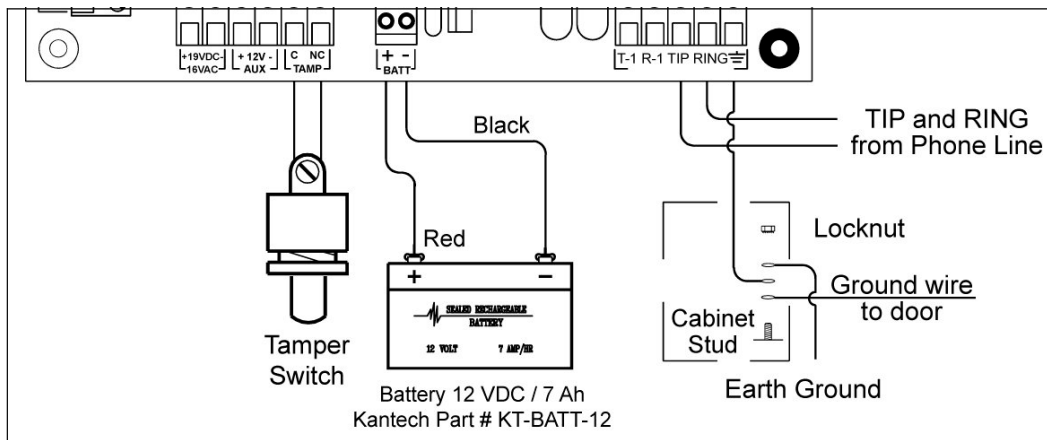
### STEP 11: Connecting Multiple TAS250 on the Same Telephone Line (optional)

It is very important to take into consideration that a maximum of 305 m (1000 ft) should be used between the first TAS250 and the last TAS250, or in total.



### STEP 12: Connect the TAS250 to Earth Ground

Since the TAS250 uses high performance communication and the telephone line, proper grounding is required to insure safety and proper operation. An AWG #18 single conductor copper wire must be used to ground each TAS250 to good earth ground as per the local electrical code (be careful with ground loops). The ground clamp should be located below any other ground.

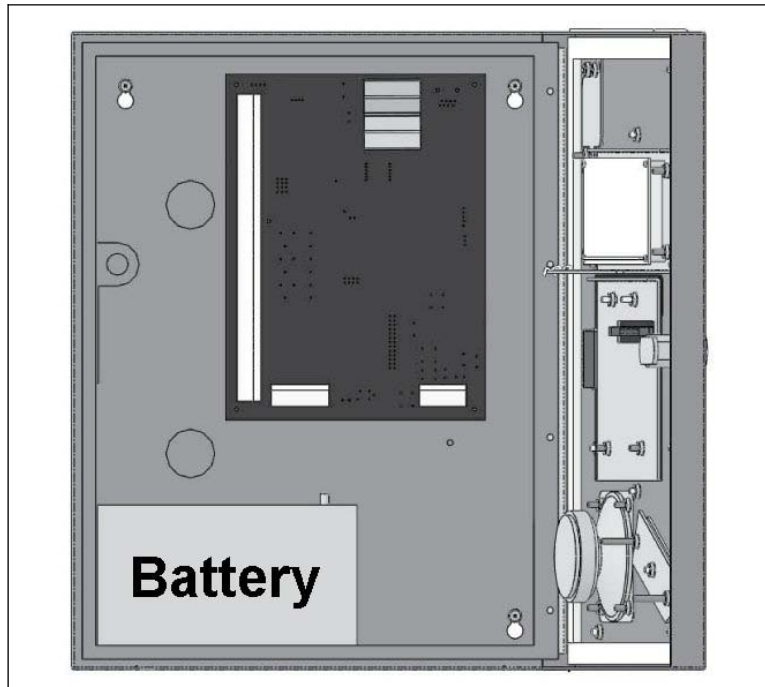


### STEP 13: Connect AC Power

Power should only be applied to the unit when all connections are completed. Connect the **16VAC** terminals to the secondary of the class 2 transformer 120 VAC 60 Hz IN / 16.5 VAC, 40 VA OUT.

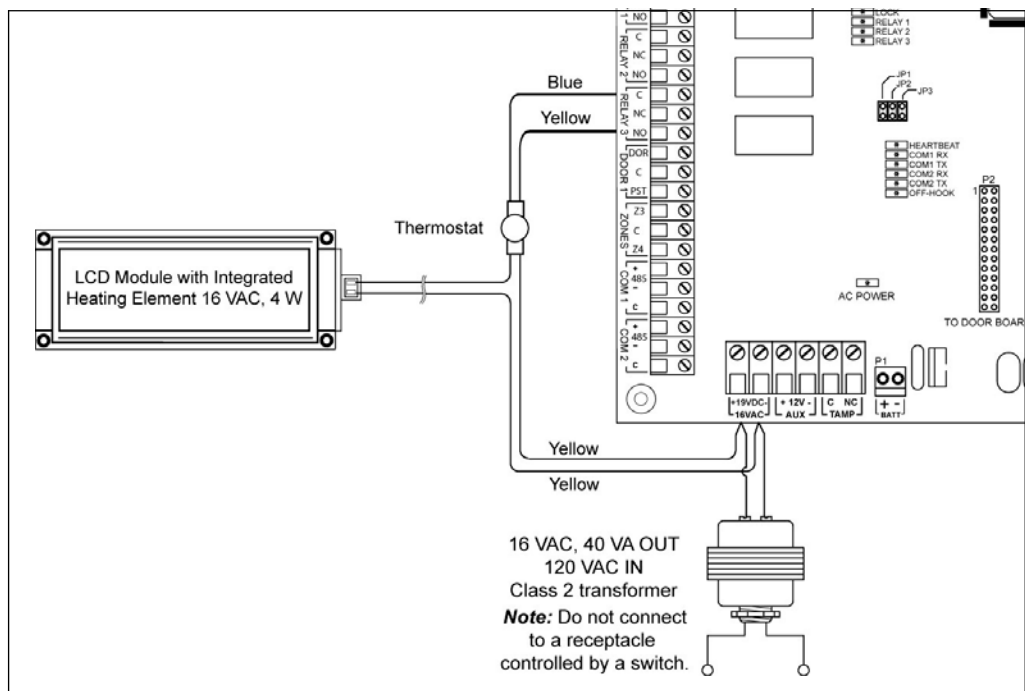
## STEP 14: Connecting the Backup Battery

The 12 VDC, 7 A/h backup battery provides operation of up to 12 hours. **Note:** The battery must be kept indoor if the outdoor temperature drops below  $-25^{\circ}\text{C}$  ( $-13^{\circ}\text{F}$ ).



## STEP 15: Connecting the Heater Kit for Outdoor Operation (Optional)

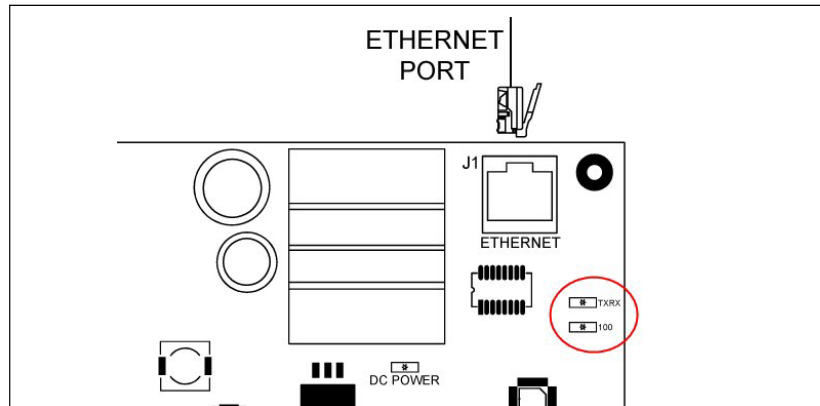
Refer to the Heater Kit Install Sheet.



---

## STEP 16: Connecting the Ethernet Cable (Optional)

Connect the Ethernet cable to the RJ-45 port.



- The TXRX (YELLOW) LED is OFF when there is no Ethernet network or the cable is disconnected; FLASHING when there is network activity; and ON when the network is present
- The 100 (GREEN) LED is ON only when the TAS250 is connected to a 100 Mb/s (100 Base-T) network.

## STEP 17: Powering Up the TAS250

Once powered, check the blue heartbeat LED status indicator to determine the status of communication and other vital parameters. Refer to the troubleshooting section for the patterns. If the main supply is removed, the 12 VDC, 7 A/h backup battery will support normal operation.

**Important:** The TAS250 will not start on backup battery alone.

## STEP 18: Programming the TAS250

If you intend to program the TAS250 remotely with an access control software like EntraPass, there are some options that must be done with the VUI before leaving the customer premises.

Enter the TAS250 programming mode by pressing and holding during 5 seconds, until you hear a beep. Type in the **Installer PIN (8888)**.

**Important:** For security reasons, keep in mind to change the default installer PIN (8888) after the **installation and configuration are completed** and give it to the owner or the maintenance dept of the building. Refer to the Tenant Menu in the *TAS250 Programming Manual*, DN1770.

### Options only Programmable with the VUI

Option Name	Keypad Shortcut
Audio Visual > Speaker Volume	8-1-2-2-1
Audio Visual > Microphone Sensitivity	8-1-2-2-2
Audio Visual > Telephone Sensitivity	8-1-2-2-3
Audio Visual > LCD Contrast	8-1-2-2-4
Audio Visual > Live Adjustment	8-1-2-2-5

**Note:** For more information on how to configure the TAS250 with the VUI, refer to the *TAS250 Programming Manual*.

# 5 - Troubleshooting

Table 4: Reset Types and Descriptions



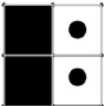

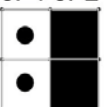

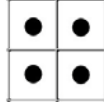
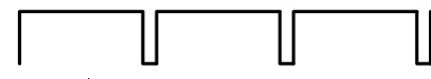
Jumpers	Heartbeat Patterns	Resets
<p>ON ON JP1 JP2</p> 	 <p>Continuous Short Pulses</p>	<p><b>Soft Reset:</b> When JP1 and JP2 are ON, the TAS250 will reset on a) power up, b) pushbutton, or c) EntraPass software 'Manual operator soft reset':</p> <ul style="list-style-type: none"> <li>All TAS250 memory definitions and parameters are verified and kept intact if still valid.</li> <li>The internal event buffer is maintained if still valid.</li> <li>IP address is kept if valid.</li> <li>The TAS250 generates the appropriate message: a) 'Power ON Soft Reset' b) 'Manual Pushbutton Soft Reset' c) 'Operator Soft Reset'.</li> </ul>
<p>ON OFF JP1 JP2</p> 	 <p>3 Long Pulses</p>	<p><b>Forced Default Static:</b> When JP1 is ON and JP2 is OFF:</p> <ul style="list-style-type: none"> <li>Same as 'Soft Reset' condition, except IP address is forced to the default static IP: 192.168.1.2.</li> </ul>
<p>OFF ON JP1 JP2</p> 	 <p>4 Short Pulses</p>	<p><b>Hard Reset:</b> When JP1 is OFF and JP2 is ON:</p> <ul style="list-style-type: none"> <li>The default installer PIN (<b>8888</b>) is restored.</li> <li>All TAS250 memory is settled to default values.</li> <li>Internal event buffer is cleared.</li> <li>IP address is kept if valid.</li> <li>TAS250 generates the message, 'TAS250 Hard Reset'.</li> <li>Internal RTC (Real Time Clock) and clock are settled to the default time and date values January 1st 2009, 00:00:00.</li> </ul>
<p>OFF OFF JP1 JP2</p> 	 <p>Continuous Long Pulses</p>	<p><b>Factory Default:</b> When JP1 and JP2 are OFF:</p> <ul style="list-style-type: none"> <li>The default installer PIN (<b>8888</b>) is restored.</li> <li>All TAS250 memory is settled to default values.</li> <li>Internal event buffer is cleared.</li> <li>TAS250 generates the message 'TAS250 Factory Default Reset'.</li> <li>Internal RTC and clock are settled to the default time and date values January 1st 2009, 00:00:00.</li> </ul>




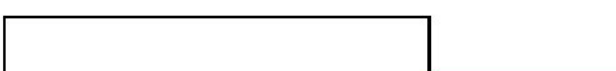






Table 5: AC and DC Power LED Status Indicators

AC Power LED	DC Power LED	Status Indicators
ON	ON	<ul style="list-style-type: none"> <li>The AC power or external AC source is present.</li> <li>The DC power level is sufficient for all DC operations such as the readers, outputs and the 12V AUX.</li> </ul>
OFF	ON	<ul style="list-style-type: none"> <li>The TAS250 is running on the 12V rechargable backup battery only.</li> <li>The DC power supply has been connected with reverse polarity, for CE compliant models only.</li> </ul>

## 6 - Heartbeat Patterns

The TAS250 status can be obtained from the **HEARTBEAT** blue LED patterns. It is located near the ribbon cable connected to the door PCB, see **Figure 8**:. This information is particularly useful when connecting the TAS250 to the EntraPass system. The following table lists all conditions along with a brief description. Refer to **Table 4**, if you must reset or change the communication mode with the TAS250.

**Table 6: Heartbeat Patterns**

Booting Up		Steady
Factory Default		Continuous LONG pulses
Forced Default Static		3 Long Pulses
Modem Initialization		Single 2.5 Sec. Burst
Dialup Communication with EntraPass		2 Short Pulses
Corporate Gateway Communication with EntraPass		3 Short Pulses
Hard Reset		4 Short Pulses
Fail Soft		Continuous Short Pulses
Firmware Update		Quick Pulses 5 pulses per sec. @ 50% duty cycle
Rebooting		Very Quick Pulses 10 pulses per sec. @ 50% duty cycle

# 7 - Hardware Default initialization

**Note:** The Soft Reset and the Hard Reset can be performed directly from the VUI, without having to open the TAS250, refer to the *TAS250 Programming Manual*.

## 7.1 How to reset the FAAC Telephone Access System for Factory Default

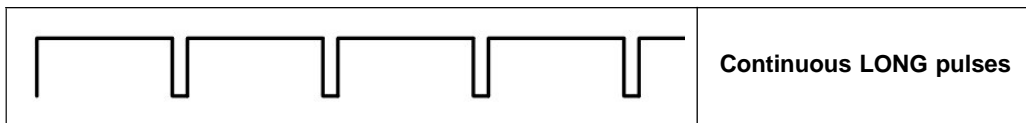
Before you start, you must be able to:

- Open the TAS250 with the key.
- Locate the reset button (SW1) and the two jumpers JP1 - JP2.
- See the flashing blue **Heartbeat** LED.

1. Remove JP1 and JP2 jumpers as described in Table 4 for Factory Default.

2. Press the reset button.

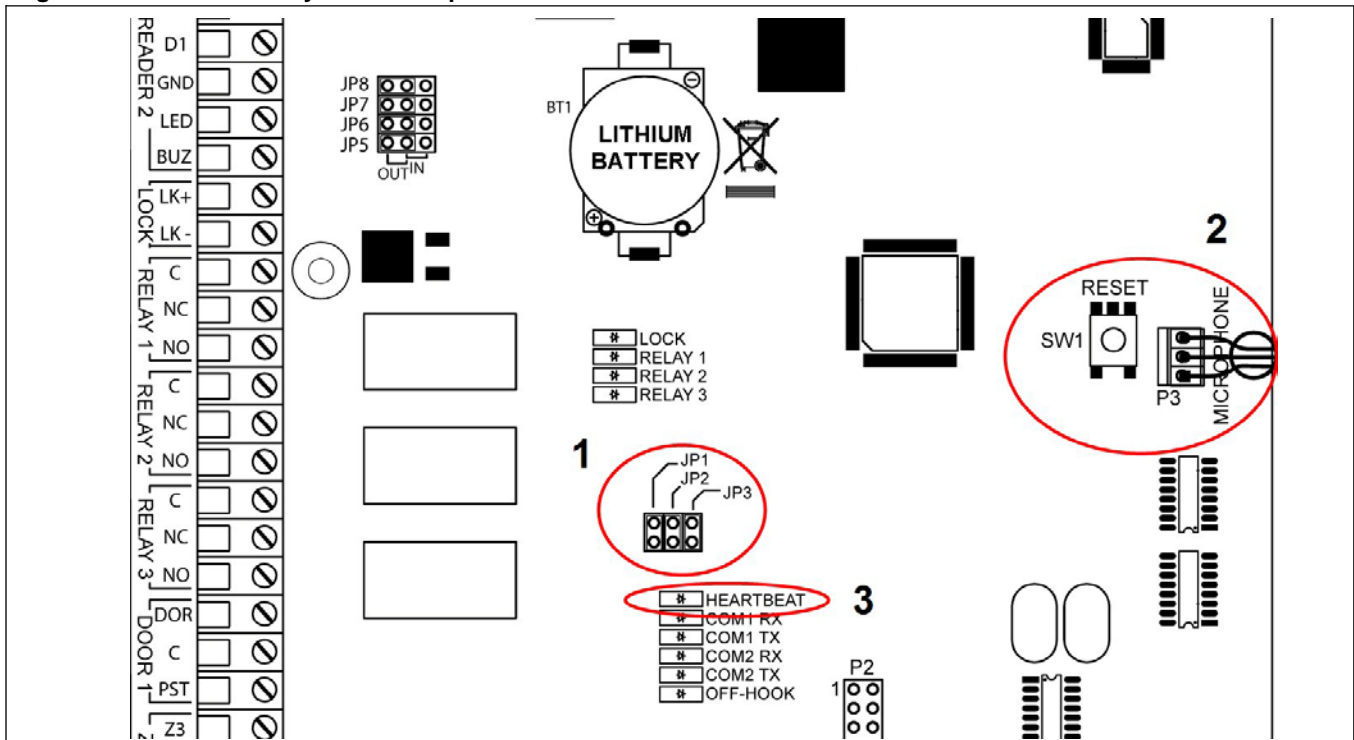
3. Check the blue **Heartbeat** LED pattern, wait until the heartbeat pattern corresponds to this:



4. Put back JP1 and JP2 jumpers, close and lock the TAS250.

5. Configure the TAS250 with the VUI, refer to the *TAS250 Programming Manual*, DN1770.

**Figure 12: TAS250 Factory Default Steps**



---

## 8 - Maintenance Recommendations

**Important:** Only a technician should perform the following maintenance recommendations.

The TAS250 includes a lithium battery (see the FAAC Telephone Access System PCB View on page 12). This battery **cant** be replaced in the field. If the lithium battery stops working, return the circuit board to FAAC. Do not crush, puncture, open, disassemble or otherwise mechanically interfere with the battery. Do not try to recharge the battery. If you need to dispose of the circuit board, wrap it in non-conductive tape.

Regarding the recommended backup battery 12 VDC / 7 Ah: It is the technician's responsibility to assure that the disposal of used batteries is made according to the waste recovery and recycling regulations applicable to the intended market. Use the recommended battery type ONLY.

**Warning:** Do not store the batteries in such a way that they come into contact with each other or with any piece of metal. Explosion or fire may occur. Should fire occur, use only dry chemical fire extinguishers. Do not use water to put out the fire. Do not heat the batteries. Do not dispose of the batteries or circuit board in a fire. Do not disassemble the batteries. Do not apply pressure to or deform the batteries. Ensure that the above precautions are strictly observed by related departments, including, but not limited to, production, sales and outside contractors.

It is highly recommended to test the TAS250 by performing the following tests:

**1. Bi-annual test for backup battery:**

Remove AC power (UL Listed) or DC power (CE Compliant) from the TAS250 and let it work on backup battery power for one hour. This test will ensure that in the event of a power failure, the backup battery will be able to support normal operations. This test should be performed twice a year. Once the test has been performed successfully, reconnect power to the TAS250.

**2. Annual test for lithium battery:**

Measure voltage when power is totally removed from the TAS250 (AC or DC and backup battery power). To ensure maximum operation and to prevent loss of the database, contact your distributor to return the TAS250 for maintenance, if the lithium battery voltage measures below 2.5 VDC.



---

# Appendix A - Installation Checklist

The following checklist enumerates the steps to install the system.

Installation Steps	Pages
<b>STEP 1: Unpacking the TAS250</b>	see page 17
<b>STEP 2: Applying Sealant on the Back of the TAS250</b>	see page 17
<b>STEP 3: Mounting</b>	see page 18
<b>STEP 4: Connecting the Door Locking Device (DC Powered)</b>	see page 19
<b>STEP 5: Connecting the Door Lock Device with an External Power Supply</b>	see page 19
<b>STEP 6: Hooking Up Inputs</b>	see page 19
<b>STEP 7: Connecting an External Controller</b>	see page 20
<b>STEP 8: Connecting a 3rd Party Controller</b>	see page 21
<b>STEP 9: Connecting the Telephone Line</b>	see page 21
<b>STEP 10: Connecting the Telephone Line with the Ferrite (TAS250-125AUS Model for Australia and New Zealand only)</b>	see page 21
<b>STEP 11: Connecting the RS-485 (optional)</b>	see page 21
<b>STEP 12: Connecting Multiple TAS250 on the Same Telephone Line (optional)</b>	see page 22
<b>STEP 13: Connect the TAS250 to Earth Ground</b>	see page 22
<b>STEP 14: Connect AC Power (North America only)</b>	see page 22
<b>STEP 15: Connect DC Power (EMEA only)</b>	see page 23
<b>STEP 16: Connecting the Backup Battery</b>	see page 23
<b>STEP 17: Connecting the Heater Kit for Outdoor Operation (Optional)</b>	see page 23
<b>STEP 18: Connecting the Ethernet Cable (Optional)</b>	see page 24
<b>STEP 19: Powering Up the TAS250</b>	see page 24
<b>STEP 20: Programming the TAS250</b>	see page 24

## LIMITED WARRANTY

To the original purchaser only:

FAAC International, Inc., warrants, for twenty-four (24) months from the date of invoice, the gate operator systems and other related systems and equipment manufactured by FAAC S.p.A. and distributed by FAAC International, Inc., to be free from defects in material and workmanship under normal use and service for which it was intended provided it has been properly installed and operated.

FAAC International, Inc.'s obligations under this warranty shall be limited to the repair or exchange of any part of parts manufactured by FAAC S.p.A. and distributed by FAAC International, Inc. Defective products must be returned to FAAC International, Inc., freight prepaid by purchaser, within the warranty period. Items returned will be repaired or replaced, at FAAC International, Inc.'s option, upon an examination of the product by FAAC International, Inc., which discloses, to the satisfaction of FAAC International, Inc., that the item is defective. FAAC International, Inc. will return the warranted item freight prepaid. The products manufactured by FAAC S.p.A. and distributed by FAAC International, Inc., are not warranted to meet the specific requirements, if any, of safety codes of any particular state, municipality, or other jurisdiction, and neither FAAC S.p.A. or FAAC International, Inc., assume any risk or liability whatsoever resulting from the use thereof, whether used singly or in combination with other machines or apparatus.

Any products and parts not manufactured by FAAC S.p.A. and distributed by FAAC International, Inc., will carry only the warranty, if any, of the manufacturer. This warranty shall not apply to any products or parts thereof which have been repaired or altered, without FAAC International, Inc.'s written consent, outside of FAAC International, Inc.'s workshop, or altered in any way so as, in the judgment of FAAC International, Inc., to affect adversely the stability or reliability of the product(s) or has been subject to misuse, negligence, or accident, or has not been operated in accordance with FAAC International, Inc.'s or FAAC S.p.A.'s instructions or has been operated under conditions more severe than, or otherwise exceeding, those set forth in the specifications for such product(s). Neither FAAC S.p.A. nor FAAC International, Inc., shall be liable for any loss or damage whatsoever resulting, directly or indirectly, from the use or loss of use of the product(s). Without limiting the foregoing, this exclusion from liability embraces a purchaser's expenses for downtime or for making up downtime, damages for which the purchaser may be liable to other persons, damages to property, and injury to or death of any persons.

FAAC S.p.A. or FAAC International, Inc., neither assumes nor authorizes any person to assume for them any other liability in connection with the sale or use of the products of FAAC S.p.A. or FAAC International, Inc. The warranty herein above set forth shall not be deemed to cover maintenance parts, including, but not limited to, hydraulic oil, filters, or the like. No agreement to replace or repair shall constitute an admission by FAAC S.p.A. or FAAC International, Inc., of any legal responsibility to effect such replacement, to make such repair, or otherwise. This limited warranty extends only to wholesale customers who buy directly through FAAC International, Inc.'s normal distribution channels. FAAC International, Inc., does not warrant its products to end consumers.

Consumers must inquire from their selling dealer as to the nature and extent of that dealer's warranty, if any. This warranty is expressly in lieu of all other warranties expressed or implied including the warranties of merchantability and fitness for use. This warranty shall not apply to products or any part thereof which have been subject to accident, negligence, alteration, abuse, or misuse or if damage was due to improper installation or use of improper power source, or if damage was caused by fire, flood, lightning, electrical power surge, explosion, wind storm, hail, aircraft or vehicles, vandalism, riot or civil commotion, or acts